

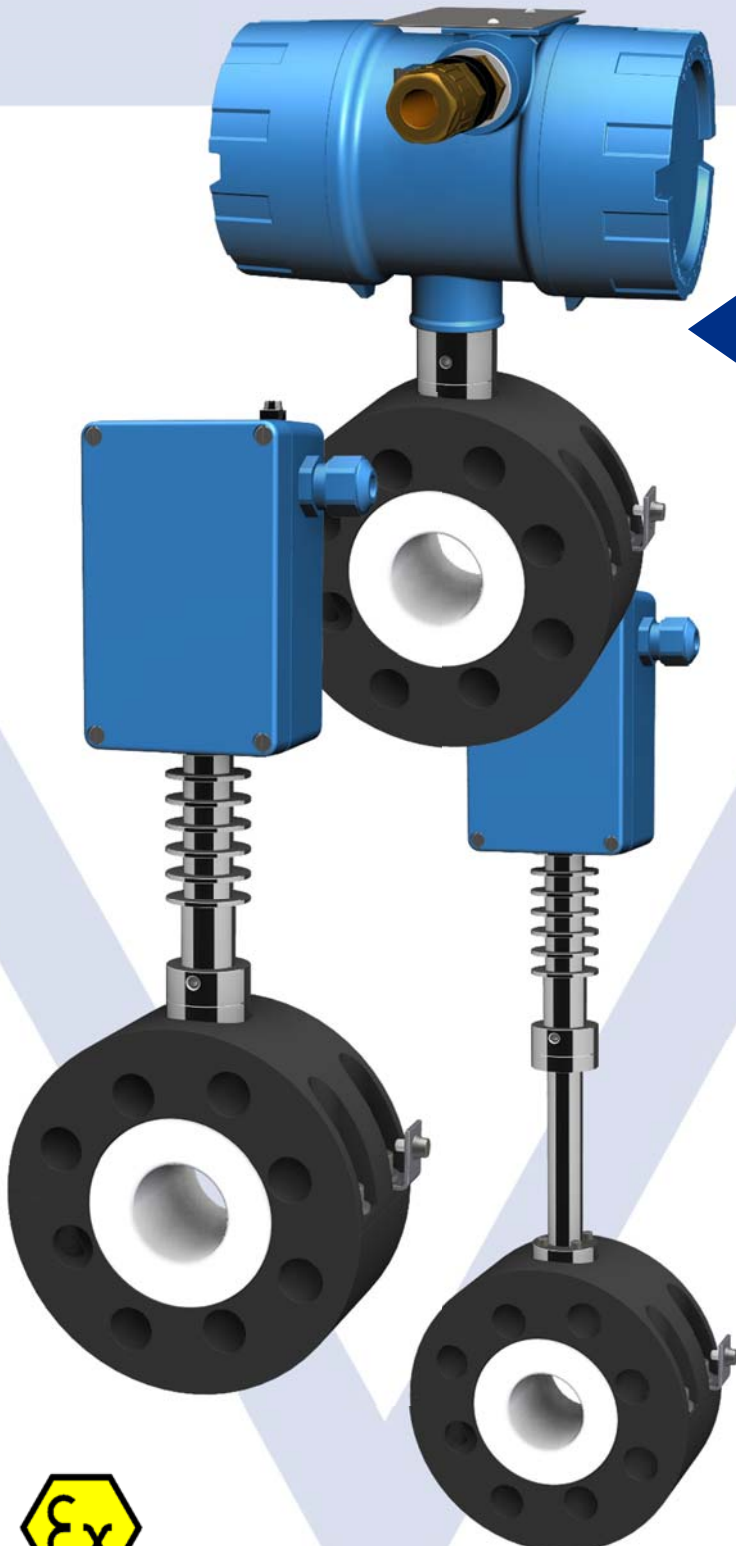

Pipe probe TSS80

Detection of interfacial layers and low-level signals



- No commissioning, plug & processing
- High-resolution measuring signal
- Pressure independent, stable measuring signal
- No moving parts
- Interfacial detection in batch operation
- Measuring electronics parameterised as in factory
- Pressure independent, stable measuring signal
- Full PTFE version Ex ia IIC

Use

Can be utilised in pipe probes after settling tanks and reactors, in single and multi-purpose plants, from pilot plant to production, as well in tank depots. For liquid/liquid phase separation of organics to aqueous media.

Application

The pipe probe flanges in the standard version are manufactured as sandwich-structured probe, combined with a PTFE inner body (including the measurement system) and combined with the aluminum housing in hard anodised aluminium with PTFE-inclusion (ALTEF® coating). The TSS80 is applied as interface pipe probe for interface detection, separation, monitoring or as empty signal.



Model code: Model options

TSS80 DN(ANS) .. SF T6 (K/KS) MTI 50/0 AG(d) ExG

TSS80		Pipe probe with PTFE measuring electrode in aluminium flange body construction Aluminium body hard-anodised with PTFE coating, optimally protected against corrosion
DN		Flange DN 32/40, 50, 80, 100 PN16 Form A as per EN 1092-1 ANSI 2, 3, 4" 150lbs ASTM A182, ASME B16,5 RF
SF		Process connection on steel flange
*(AF)		<i>Process connection on Aseptic steel flange)</i>
T(6)		Teflon® TFM® 1600 measuring body s = 1.4 mm
*(Td)		<i>spez. PTFE body; s = 3.75 mm, iø -5 mm (z.B. DN50 = iø 45 mm)</i>
*(K)		Cooling gills stainless steel (<-20 / >100 max. 170 °C)
*(S)		<i>with extension L = 100 mm for insulated lines</i>
MTI		Built in measuring electronics device, selected according to process condition 50/.. (30) AEE2 K
*(H)		<i>Anti-static version; overvoltage protection up to 50 kV)</i>
*(F3)		Only for phase separation with media with el. conductivity up to 4000 µS/cm, higher measuring frequency)
A		Analogue measurement technology for interphase detection, product monitoring, full and empty signal
G		Measuring electronics – protective housing, 360° rotatable fixed with adjustment screw, indoor, blue RAL 5007, seal: Viton, cable gland PM M16 × 1.5, cable clamping range 6-8 mm, IP 65 to EN 60529
*(Gd)		<i>Measuring electronics protective housing, pressurised encapsulation (outdoor installations), measuring electronics protective housing (indoor installations), assembled, 360° rotatable, fastened, blue powder-coated assembled, 360° rotatable, fastened, blue</i>

Probe Ex protection: SEV 09 ATEX 0133 X CE 0036/1254

ExG | (Gas) Ex version (probe/MTI) II 1/2 G Ex ia IIC T6 Ga/Gb

*(ExdG | (Gas) Ex version (probe/MTI) II 1/2 G Ex d ia IIC T6 Ga/Gb)

*(.) Configuration options

Technical data pip probe

Temperature range:

-20 .. +100°C medium | with Cooling gills -20 .. +170°C
connection head -20 .. + 60°C

Cleaning temperature 210 °C max. 10 min pressureless (CIP, SIP)

Pressure -0.5 bar to max. 16 bar / 150 lbs. standard

Measuring principle Impedance

Measuring range DK 1.20 ... > 80

Optimum of conductivity of the organic phase for interface detection

MTI Standard: 0...150 µS/cm / F3: 0...4000 µS/cm

Integration time 40-400 ms / 0-3750 Imp

Measuring electrode PTFE-layer thickness PTFE s = 1.4 mm

Application Interface detection for separation and monitoring

Measuring electronics Round plug-in housing MTI 50/0 AEO2K

Protection probe head round IP68 separation

Measuring electrode housing | Protection class as per EN 60529

G | IP65; Aluminium, seal FPM

Screwed cable gland, polyamide, Ex M16 x 1.5 (M20 x 1.5)
Cable clamping range ø 6-8 mm (8-11 mm)

Gd | IP68; Aluminium (pressurised encapsulation), seal silicone

Screwed cable gland, polyamide, blue Ex M20x1.5
Cable clamping range 8-11mm

Ex d version with EX/flameproof execution: up to 1000m
Connection line

Screwed cable gland, brass, Exd M20x1.5,
Cable clamping range 9.5-16mm)

Measuring electronics

G | Standard housing (square): MTI 50/.. AEE2K

Gd | pressurised encapsulated housing (round): MTI 50/.. AEO2K

Wiring

Shielded 2-core cable 0.75 mm² twisted CY/EIG to all evaluation devices
mipromex® cable length up to 200 m or max. C= 120 nF /
R = 30 Ohm line impedance

Connection to evaluation unit mipromex® MIQ / MAT / MLS

Article no. 02.29.11.0000 xxxx

Technical data on-site MTI measuring electronics

Design type

Plug-in electronics with square stainless cover in the protective housing, with HF-connection; IP 20

Installation

Protection housing with mounting holes, plug-in electronics pluggable, fixed with 2 screws M4x8

Performance

Linear conversion of an impedance range into a normed digital measurement signal

Use / Display

One-time compensation of basic capacity of the RF cable and uncovered dry probe, LED display for quick adjustment

Dimensions electronics

Square version height x width x length 51 x 70 x 77 mm
Round model diameter x height \varnothing 85 x 51 mm

Weight electronics

140 g

Ex power supply / connection wiring

Shielded two-wire connection 0.75 mm² twisted CY/EIG to all evaluation devices mipromex® cable length up to 200 m or max. C= 120 nF / R = 30 Ohm line impedance

Transfer signal

Impulse parcel, superimposed on the supply current

Measuring voltage / current

U ~ 14.5 V I ~ 13.5 mA

Nominal data of the supply voltage

Rate data **Ex ia IIC** only for connection to mipromex®-or *TI*K-units
Circuit with the following maximum output values

$U_i \leq 18.9 \text{ V}$ $I_i \leq 49 \text{ mA}$

$P_i \leq 231 \text{ mW}$

$C_i = 60 \text{ nF}$ $L_i = 0 \text{ mH}$

For ignition protection type flameproof enclosure and intrinsic safety, **Ex d ia IIC** only for connection to mipromex® Typ M** **** *

Circuit with the following maximum output values

$U \leq 19.3 \text{ V}$ $I \leq 75 \text{ mA}$

Ambient temperature

-20 ...+60 °C

Storage temperature

-30 ...+80 °C, ideal +20 °C

Measuring range

10 / 20 / 50 / 100 / 200 / 300 respective 0 up to max. 3750 impulses, special ranges available. The resolution range depends on the probe dimension and is product specific.

Resolution

Max. 0.003 pF/impulses

Norm range for pipe probe with remote MTI housing

Type TSS80 .../100/200/300
55 pF, type MTI 30/, 50/(0 - 16) basic adjustment range depending on probe and RF cable length, determined by the manufacturer

Basic adjustment range

MTI .../. 0 to 16, 0 to 500 pF

Measurement frequency

~ 500 kHz

Linearity

Deviation < 0,1 % (without probe)

Hysteresis

1 measured impulse

Temperature influence 5 – 45 °C

Type MTI .../.A analogue: < \pm 3 measuring impulses

Certification

Gas  II 1/2G Ex ia Gb IIC T6
Dust II 1/2D Ex iaD 20/21 IP65 T85°C
II 1/2G Ex d ia IIC T6
RL 2014/34/EU

Inspection report no.: 08-IK-0395.01 with extension 1
Unit can be supplied without Ex protection

Intrinsically safe Ex connection:

Measuring electronics MTI ... in a protective housing or tube probe type TSS80

EMC-tested, STS 024 report no. 990102WS

corresponds to EN 1127-1 : 20011

EN 61000-6-2 2005 EN 6100-6-4 : 2007

EN 60079-0 : 2012 EN 60079-11 : 2012



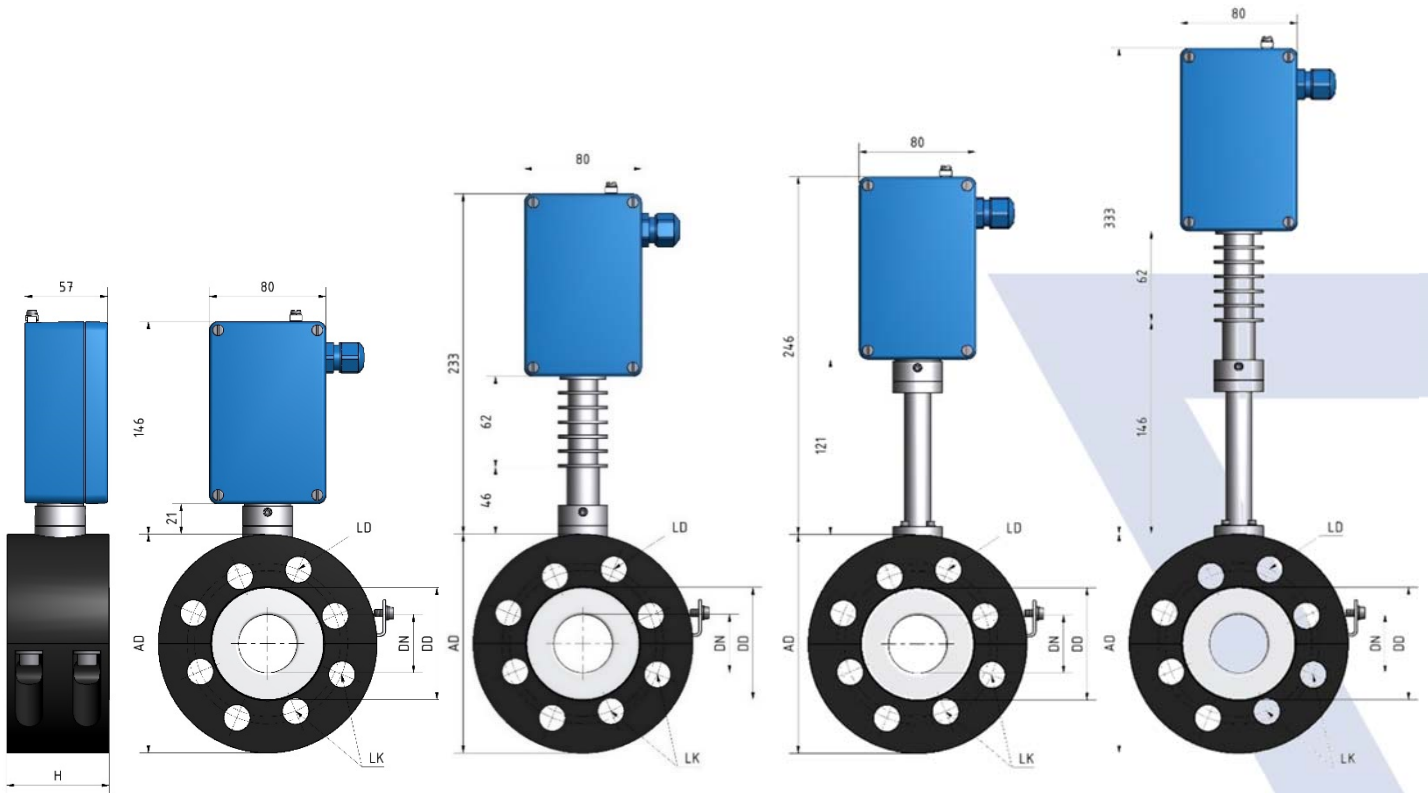

Options and masses of the TSS80 pipe probe

The pipe probe versions are configured for specific applications, dependent on the process conditions. For indoor installations, the standard housing IP 65 (125x80 mm) is used, and for outdoor installations the pressurised encapsulated housing IP 68 (186xø110 mm). To align the probe head, the M6 grub screw must be loosened radially underneath the connection nipple. Turn the probe head to the desired position and fasten with the grub screw. For temperatures > 80 °C to max. 170 °C, a cooling element must be used. Housing connection extensions for insulated lines are mandatory. For connection to lines with plastic inliners, enamel coatings or loose-type flanges, a special PTFE-coated flat gasket with earthing lug from aquasant® must be used.

Dimensions of the pipe probe versions

Nominal diameter	OD	DN	LD drill hole	LK	DD	Installation H	Weight
DN 32/40	150	32/40	8 x ø 18	100/110	77	70	
DN 50	165	50	4 x ø 18	125	97	92	
DN 80	200	80	8 x ø 18	160	123	74	
DN 100	220	100	8 x ø 18	180	146	74	
ANSI 2"	152.4	50	4 x ø 19.1	120.7	97	92	
ANSI 3"	190.5	80	4 x ø 19.1	152.4	123	74	
ANSI 4"	228.6	100	8x19.1	190.5	146	74	

Connection to MTI-unit:
 Length x Width x Depth
 125 x 80 x 57 mm
 Extension:
 Insulation thickness max. 100 mm

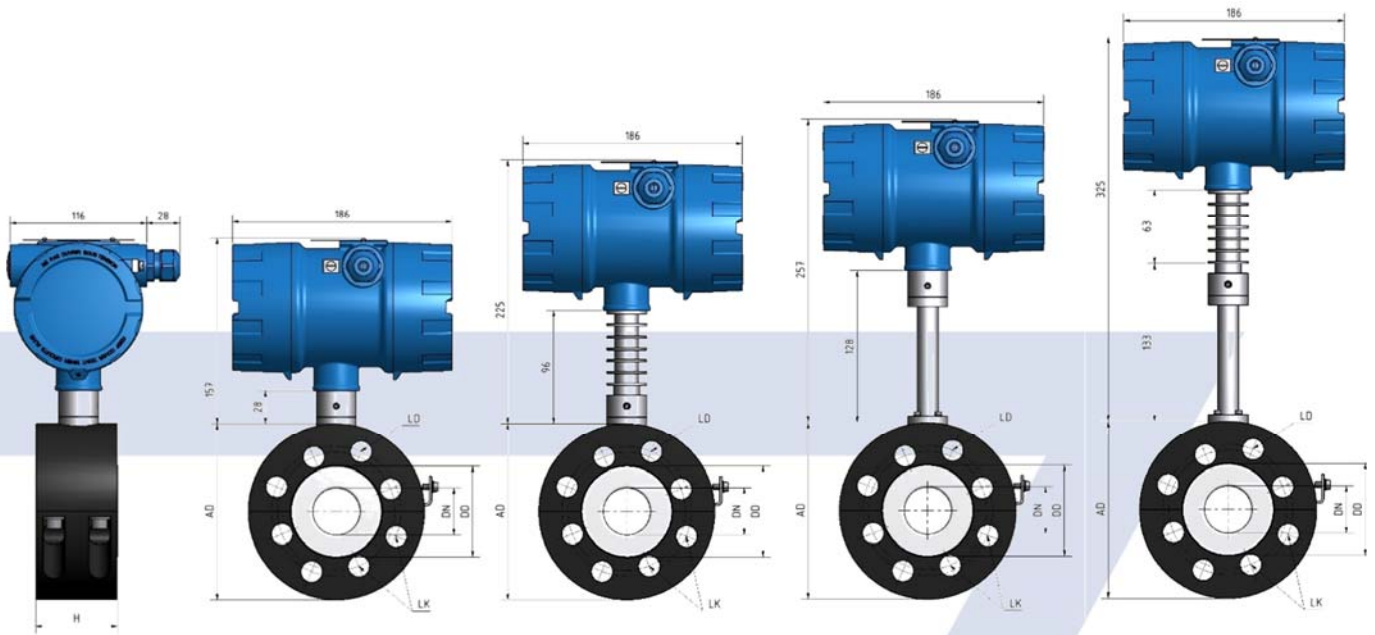

Measuring equipment

The measuring system consists of probes with attached or remote on-site MTI measuring electronics and mipromex® evaluation unit in the non-hazardous zone. The max. cable length for Ex ia applications is 200 m, for Ex d applications 1000 m.

Measuring principle

The pipe probe, filled with product, changes the impedance in function of the dielectric and conductive properties of organic products and aqueous solutions, as well as the partial filling of horizontally installed pipe probes.

Measured values

The measured impedance sum signal is converted directly by the MTI measuring electronics into a normed signal and is transmitted as an impulse parcel to the mipromex®.

The dielectric constant and the electrical conductivity, as well as the dimensions of the probe, have a direct effect on the resulting measuring signal. False effects result from strong temperature changes after saving the zero point. Organic contaminations on the active measuring electrode are negligible. Conductive contaminations lead to severe measured value errors and to a constant high-level indication, depending on the set-up.

Nominal width	Measuring electronics	Product	DK value at 20°C	Measured value in Imp.
DN32/40	MTI 30/0 AEE2K	Mains water 500 µS	80.0	2960-2980
		Demin. water 2.5 µS	80.0	1940-1950
		Toluene	2.4	110-125
		Ethanol	25.0	1100-1120
DN50 / ANSI 2"	MTI 50/0 AEE2K	Mains water 500 µS	80.0	2700-2800
		Demin. water 2.5 µS	80.0	1600-1700
		Toluene	2.4	80-90
		Ethanol	25.0	1000-1100
DN80 / ANSI 3"	MTI 50/0 AEE2K	Mains water 500 µS	80.0	2500-2700
		Demin. water 2.5 µS	80.0	1700-1800
		Toluene	2.4	140-150
		Ethanol	25.0	1300-1400
DN100 / ANSI 4"	MTI 50/0 AEE2K	Mains water 500 µS	80.0	2900-3000
		Demin. water 2.5 µS	80.0	2100-2300
		Toluene	2.4	180-190
		Ethanol	25.0	1700-1800

The graphic shows the measuring behaviour of a pipe probe TSS80 DN50 dependent on the dielectric constant

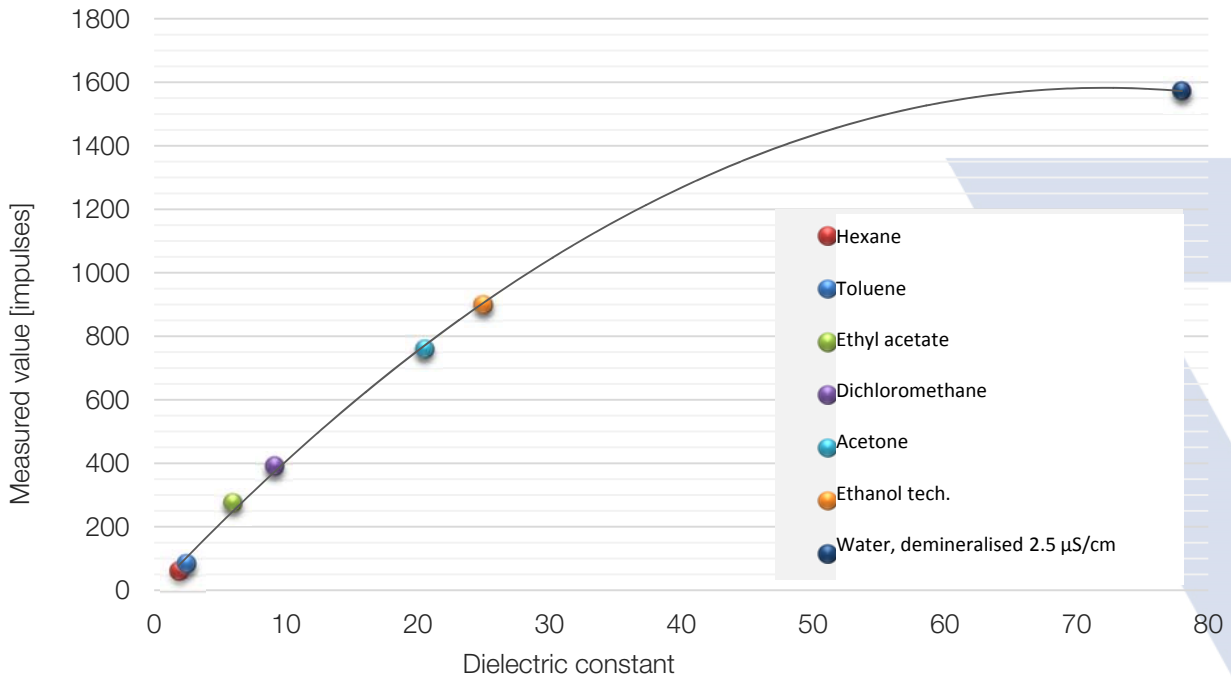

The graphic shows the measuring behaviour of a pipe probe TSS80 DN50, dependent on the electr. conductivity of water, between standard and F3 measuring electronics MTI from 0 to 4000 µS/cm.

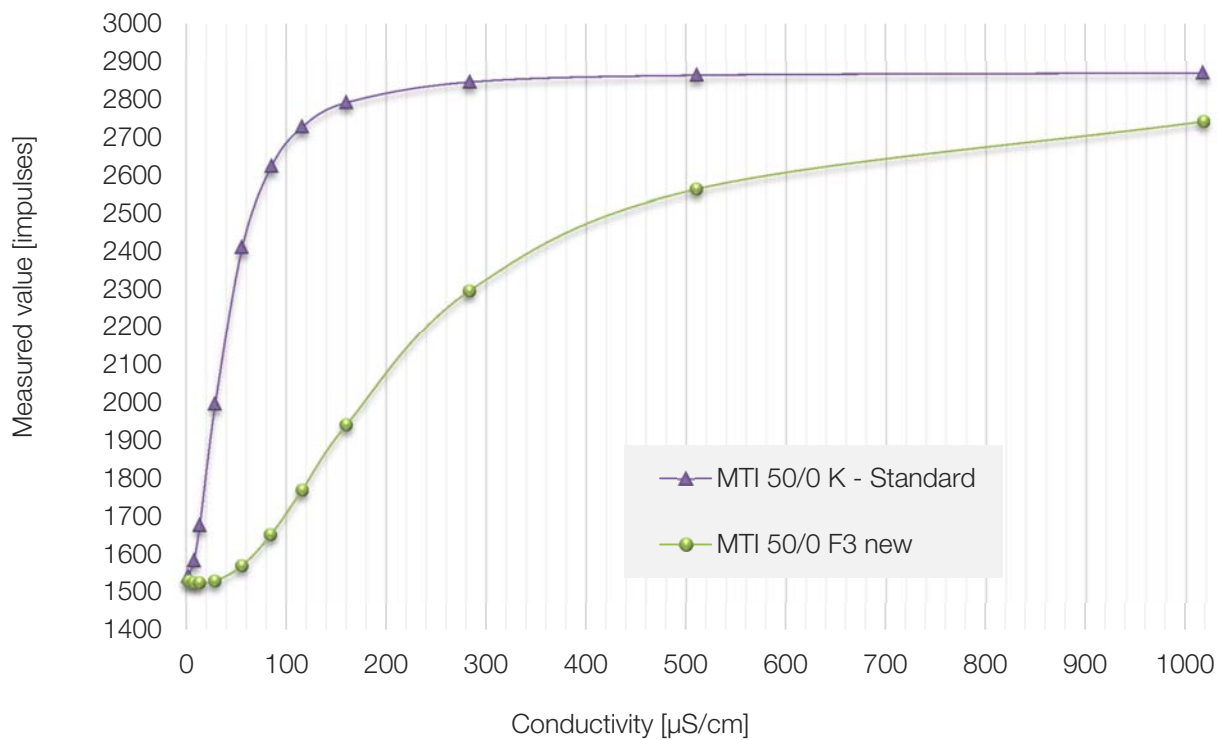

Mounting directions

- Installation position of a 3 % slope to vertical, depending on the application (see mounting directions for TSS)
- Installation independent of the flow direction
- Installation between two smooth flanges or flared, loose flanges only with special installation protection gaskets
- Caution! Note flange to flange distance for different nominal widths, the PTFE core protrudes on both sides by 0.2 mm
- Additional flat gaskets "Gylon" protect the PTFE core (with appropriate tightening torque)
- Internal installation guidelines must always be followed and suitable sealing types used.
- Observe internal safety regulations for open tanks
- Installation in pipes with appropriate nominal diameter with flat gasket and tightening torques (see mounting directions for TSS80)
- The pipe insulation must not enclose the cooling rod
- Ambient temperature: max. allowed temperature in the connection head must not exceed +60 °C, if pipe probe is insulated and measuring electronics is remote installed
- The connection electronics MTI must be mounted at pipe temperatures of >60 °C horizontal or downwards and with the adjustment screw fixed in any 360° position.
- Pressure tests must be conducted with assembled probe
- Caution! Probe body is only leak-proof when flanged in.

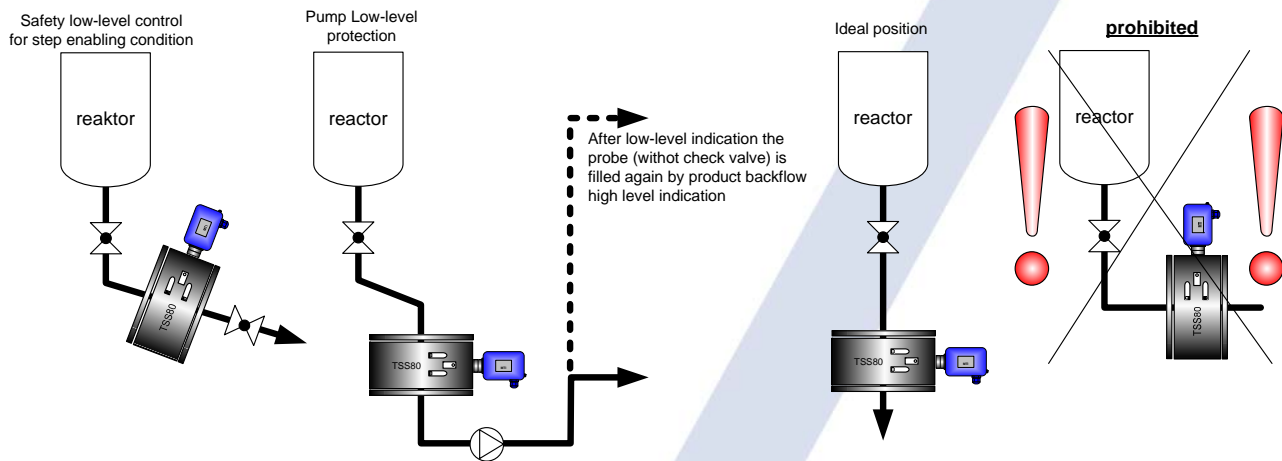

Disassembly instructions

- Empty tank and flush with nitrogen or water according to operating instructions (observe internal safety regulations)
- Disconnect electrical connections. Dismount probe, lift at the flange. Caution, residual liquid may leak out
- Data sheets for personal security purpose need to be enclosed with repair shipments to aquasant.

Electrical directions

- Wiring must comply with the circuit and grounding diagram.
- Connections to MTI clamps 1/2, protected against polarity reversal, suitable for wire cross section 0.2 – 1.5 mm²
- The connecting cable has to suit the demands at the measuring circle.
- MTI-housing lid in [Ex ia] zone can be opened under live-line working.
- Output signal of mipromex® is a pulse modulated signal $U_0 \leq 18.9 \text{ V}$

Basic circuit diagram

Probe connection to evaluation unit mipromex® Connection diagram MRM2 Monorack DIN housing

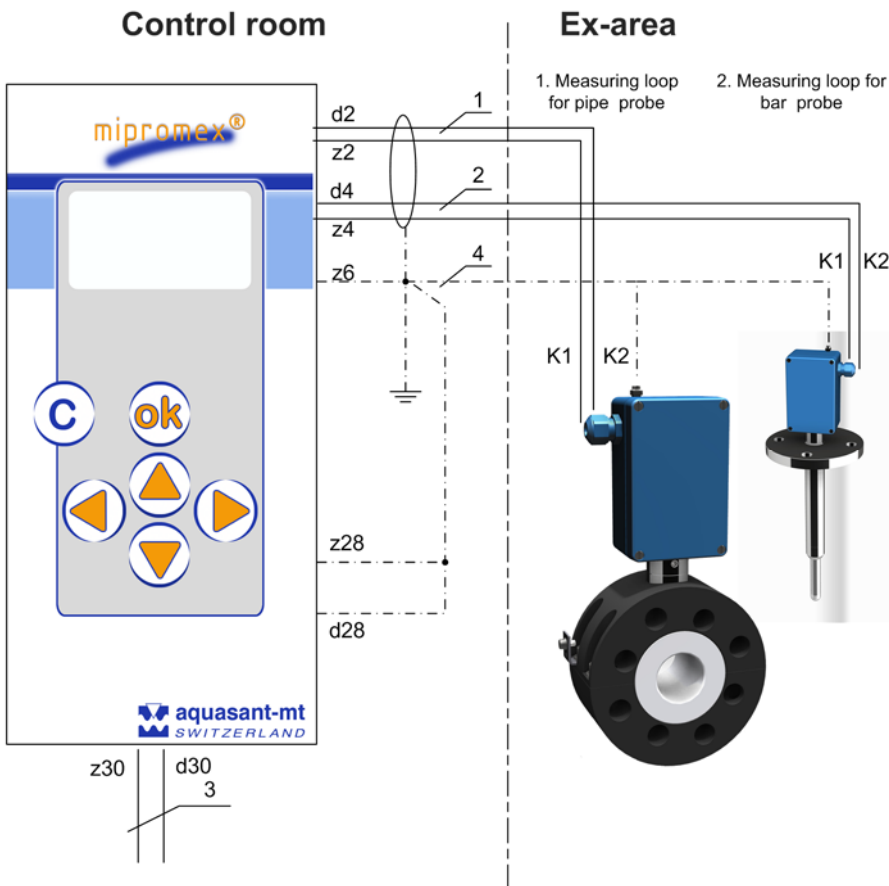

Certificates

Explosion protection (ATEX)

EC-type examination SEV 09 ATEX 0133 X

- Ex certification according to the directive 2014/34 EU

- Confidential test report no: 08-IK-0395.01

CE-Mark

The probe fulfills the legal requirements according to the EC directives. CE 1254

Pressure Equipment Directive

The probe fulfills the requirements in accordance with

2014/68/EU Module A2